

F01 Series 1A TRIACs

FEATURES

- Glass Passivated Junctions
- High voltage and surge capability
- Low Thermal Resistance and Durability
- Triggering in all four quadrants

APPLICATIONS

- Heating regulation
- In-duction motor starting circuits
- Phase control operation in light dimmers
- Motor speed controllers



Parameters Summary

VD/VR:600/800V IT(RMS):1A IGT:3mA

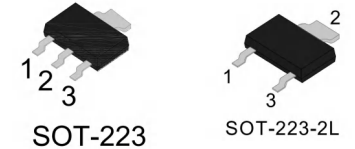
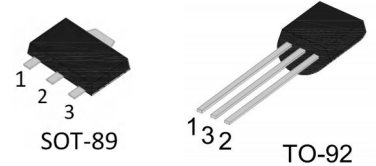
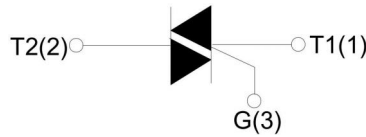

ABSOLUTE MAXIMUM RATINGS

Parameter	Symbol	Value	Unit	
Storage junction temperature range	Tstg	-40 ~150	°C	
Operating junction temperature range	Tj	-40~125	°C	
Repetitive peak off-state voltage (T =25°C)	V _{DRM}	600/800	V	
Repetitive peak reverse voltage (T =25°C)	V _{RRM}	600/800	V	
Non repetitive surge peak Off-state voltage	V _{DSM}	V _{DRM} +100	V	
Non repetitive peak reverse voltage	V _{RSM}	V _{RRM} +100	V	
RMS on-state current	SOT-89/SOT-223/SOT-223-2L (TC=70°C)	I _{T(RMS)}	1	A
	TO-92 (TC=51°C)			
Non repetitive surge peak on-state current (180° conduction angle, F=50Hz)	I _{TSM}	12	A	
I ² t value for fusing (tp=10ms)	I ² t	0.72	A ² S	
Critical rate of rise of on-state current (I =2×IGT, tr ≤ 100 ns)	di/dt	20	A/μS	
Peak gate current	I _{GM}	1	A	
Average gate power dissipation	P _{G(AV)}	0.5	W	

Thermal Resistances

Symbol	Parameter	Value	Unit	
Rth(j-c)	Junction to case (AC)	TO-92	60	°C/W
		SOT-89	30	
		SOT-223	30	
		SOT-223-2L	30	

ELECTRICAL CHARACTERISTICS (T=25°C unless otherwise specified)					
Symbol	Test Condition	Quadrant		Value	Unit
				03	
I_{GT}	$V_D=12V$	I-II-III	MAX	3	mA
		IV		7	
V_{GT}		ALL	MAX	1.3	V
V_{GD}	$V_D=V_{DRM}$ $T_j=125^\circ C$	ALL	MIN	0.2	V
I_L	$I_G=1.2I_{GT}$	I -III	MAX	5	mA
		II -IV		15	
I_H	$I_T=200mA$		MAX	5	mA
dV/dt	$V_D=2/3V_{DRM}$ Gate Open $T_j=125^\circ C$		MIN	20	V/ μs

STATIC CHARACTERISTICS				
Symbol	Parameter		Value(MAX.)	Unit
V_{TM}	$I_{TM}=1.4A$ $t_p=380\mu s$	$T_j=25^\circ C$	1.5	V
I_{DRM}	$V_D=V_{DRM}$ $V_R=V_{RRM}$	$T_j=25^\circ C$	5	μA
I_{RRM}		$T_j=125^\circ C$	5	mA

Ordering Information Scheme

F 01 03 - 8 U

F:4Q

IT(RMS):1A

03:IGT≤3mA

E:SOT-89 U:TO-92

W:SOT-223 V:SOT-223-2L

6:VD/VR≥600V

8:VD/VR≥800V

SOT-89 Package Mechanical Data

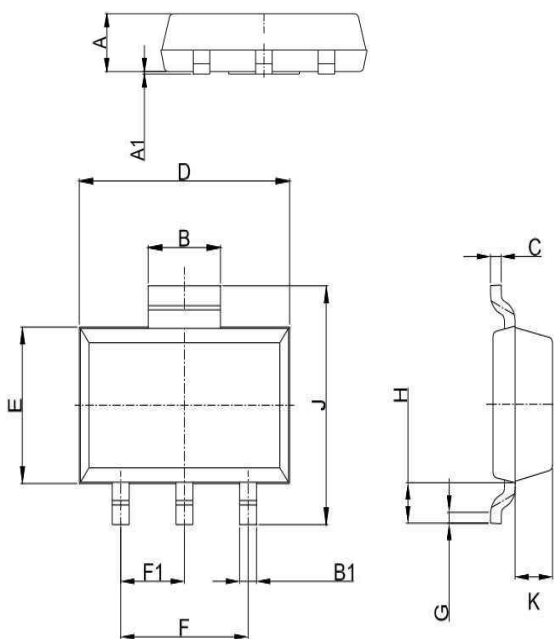

Ref.	Dimensions					
	Millimeters			Inches		
	Min.	Typ.	Max.	Min.	Typ.	Max.
A	1.3	1.4	1.5	0.051	0.055	0.059
A1	0.01	0.06	0.10	0.001	0.002	0.004
B	1.6	1.7	1.8	0.063	0.067	0.071
B1	0.3	0.4	0.5	0.012	0.016	0.020
C	0.22	0.254	0.32	0.009	0.010	0.013
D	4.75	4.95	5.15	0.187	0.195	0.203
E	2.75	2.95	3.15	0.108	0.116	0.124
F		3.0			0.118	
F1		1.5			0.059	
G	0.2	0.3	0.4	0.008	0.012	0.016
H	0.58	0.78	0.98	0.023	0.031	0.039
J	4.3	4.5	4.7	0.169	0.177	0.185
K		0.88			0.035	

TO-92 Package Mechanical Data

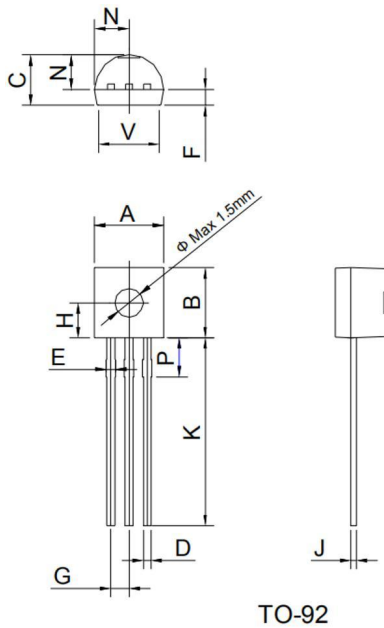

Ref.	Dimensions					
	Millimeters			Inches		
	Min.	Typ.	Max.	Min.	Typ.	Max.
A	4.45		5.20	0.175		0.205
B	4.32		5.33	0.170		0.210
C	3.18		4.19	0.125		0.165
D	0.254		0.506	0.016		0.021
E	0.30		0.70	0.024		0.031
F	.	1.30	.	.	0.051	-
G	.	1.27	.	.	0.050	-
H	.	2.30	.	.	0.091	-
J	0.30		0.50	0.011		0.020
K	12.70		15.0	0.500		0.591
N	2.04		2.66	0.080		0.105
P	1.86		2.06	0.073		0.081
V	.		4.50	.		0.169

SOT-223 Package Mechanical Data

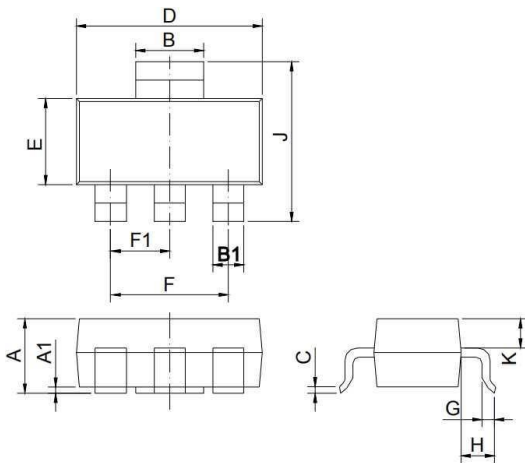

Ref.	Dimensions					
	Millimeters			Inches		
	Min.	Typ.	Max.	Min.	Typ.	Max.
A	1.5	1.6	1.8	0.059	0.063	0.071
A1	0.01	0.06	0.10	0.001	0.002	0.004
B	2.9	3.0	3.1	0.114	0.118	0.122
B1	0.6	0.7	0.8	0.024	0.028	0.031
C	0.22	0.26	0.32	0.009	0.010	0.013
D	6.3	6.5	6.7	0.248	0.256	0.264
E	3.3	3.5	3.7	0.130	0.138	0.146
F		4.6			0.181	
F1		2.3			0.091	
G	0.7	0.9	1.1	0.028	0.035	0.043
H	1.5	1.75	2	0.059	0.069	0.079
J	6.7	7.0	7.3	0.264	0.276	0.287
K		0.9			0.035	

SOT-223-2L Package Mechanical Data

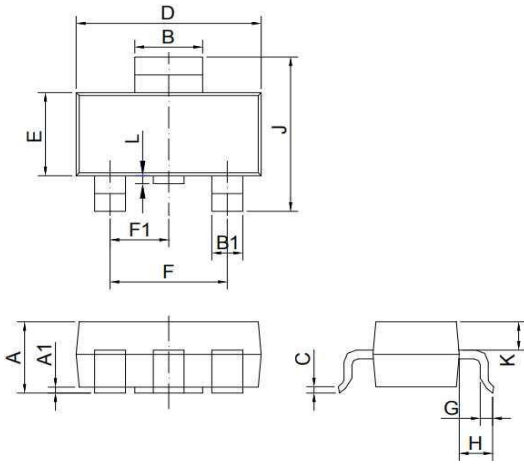

Ref.	Dimensions					
	Millimeters			Inches		
	Min.	Typ.	Max.	Min.	Typ.	Max.
A	1.5	1.6	1.8	0.059	0.063	0.071
A1	0.01	0.06	0.10	0.001	0.002	0.004
B	2.9	3.0	3.1	0.114	0.118	0.122
B1	0.6	0.7	0.8	0.024	0.028	0.031
C	0.22	0.26	0.32	0.009	0.010	0.013
D	6.3	6.5	6.7	0.248	0.256	0.264
E	3.3	3.5	3.7	0.130	0.138	0.146
F		4.6			0.181	
F1		2.3			0.091	
G	0.7	0.9	1.1	0.028	0.035	0.043
H	1.5	1.75	2	0.059	0.069	0.079
J	6.7	7.0	7.3	0.264	0.276	0.287
K		0.9			0.035	
L	0	0.1	0.2	0	0.004	0.008

FIG.1 Maximum power dissipation versus on-state current

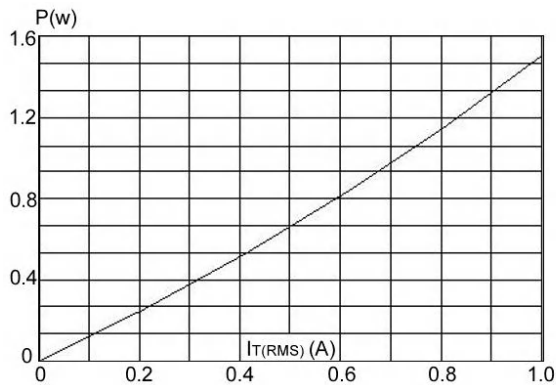

FIG.2: on-state current versus case temperature

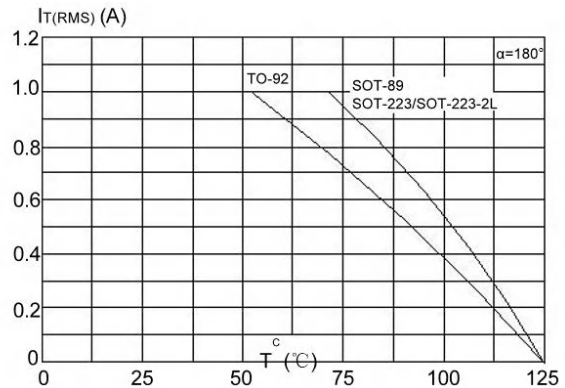

FIG.3: Surge peak on-state current versus number of cycles

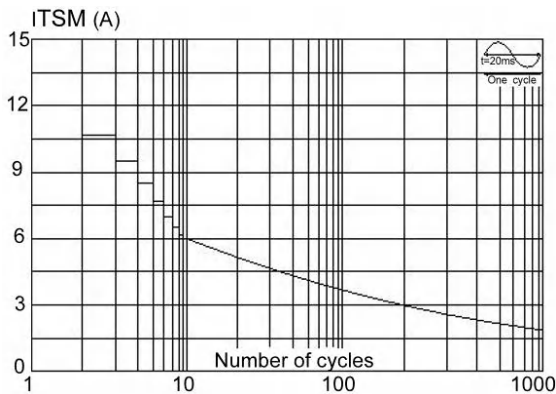

FIG.4: On-state characteristics (maximum values)

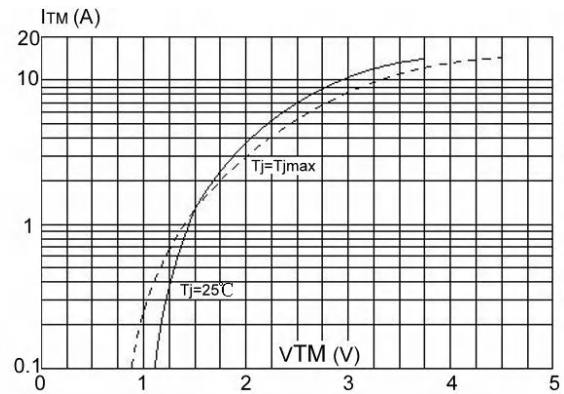

FIG.5: Non-repetitive surge peak on-state current for a sinusoidal pulse with width $t_p < 10\text{ms}$, and corresponding value of $I_2 t$ ($di/dt < 50\text{A}/\mu\text{s}$)

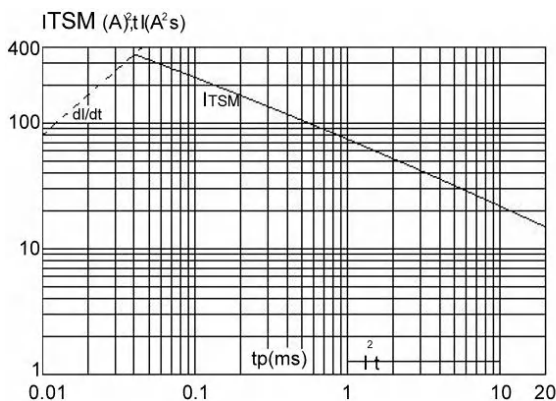
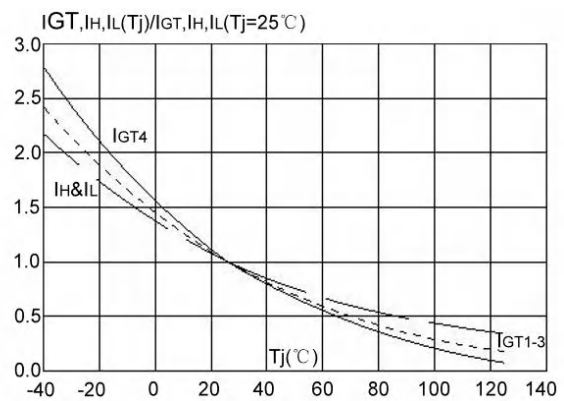

FIG.6: Relative variations of gate trigger current holding current and latching current versus junction temperature



Disclaimer

All product specifications and data are subject to change without notice.

For documents and material available from this datasheet, Jiangsu Jilai Microelectronics Co., Ltd does not warrant or assume any legal liability or responsibility for the accuracy, completeness of any product or technology disclosed hereunder.

No license, express or implied, by estoppels or otherwise, to any intellectual property rights is granted by this document or by any conduct of Jiangsu Jilai Microelectronics Co., Ltd

The products shown herein are not designed for use in medical, life-saving, or life-sustaining applications unless. Customers using or selling Jiangsu Jilai Microelectronics Co., Ltd products not expressly indicated for use in such applications do so entirely at their own risk and agree to fully indemnify Jiangsu Jilai Microelectronics Co., Ltd for any damages arising or resulting from such use or sale.

Jiangsu Jilai Microelectronics Co., Ltd disclaims any and all liability arising out of the use or application of any product described herein or of any information provided herein to the maximum extent permitted by law. The product specifications do not expand or otherwise modify Jiangsu Jilai Microelectronics Co., Ltd 's terms and conditions of purchase, including but not limited to the warranty expressed therein, which apply to these products.

Jiangsu Jilai Microelectronics Co., Ltd strives to supply high-quality high-reliability products. However, any and all semiconductor products fail with some probability. It is possible that these probabilistic failures could give rise to accidents or events that could endanger human lives that could give rise to smoke or fire, or that could cause damage to other property. When designing equipment, adopt safety measures so that these kinds of accidents or events cannot occur. Such measures include but are not limited to protective circuits and error prevention circuits for safe design, redundant design, and structural design.

In the event that any or all Jiangsu Jilai Microelectronics Co., Ltd products(including technical data, services) described or contained herein are controlled under any of applicable local export control laws and regulations, such products must not be exported without obtaining the export license from the authorities concerned in accordance with the above law.

Information (including circuit diagrams and circuit parameters) herein is for example only; it is not guaranteed for volume production. Jiangsu Jilai Microelectronics Co., Ltd believes information herein is accurate and reliable, but no guarantees are made or implied regarding its use or any infringements of intellectual property rights or other rights of third parties.