

Feature

- -30V,-10A
 $R_{DS(ON)} < 23m\ \Omega @ V_{GS} = -10V$
 $R_{DS(ON)} < 34m\ \Omega @ V_{GS} = -4.5V$
- Trench DMOS Power MOSFET
- Fast Switching
- Exceptional on-resistance and maximum DC current capability

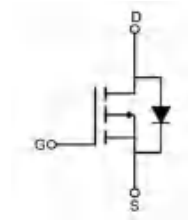

Schematic diagram

Application

- DC/DC Converter
- Load Switch for Portable Devices
- Battery Switch

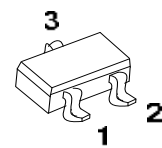

SOT23-3

Package Marking and Ordering Information

Device Marking	Device	Device Package	Reel Size	Tape width	Quantity (PCS)
3101A	AP3101A	SOT23-3	13 inch	-	3000

ABSOLUTE MAXIMUM RATINGS ($T_a = 25^\circ\text{C}$ unless otherwise noted)

Parameter	Symbol	Value	Unit
Drain-Source Voltage	V_{DS}	-30	V
Gate-Source Voltage	V_{GS}	± 20	V
Continuous Drain Current ($T_a = 25^\circ\text{C}$)	I_D	-10	A
Continuous Drain Current ($T_a = 100^\circ\text{C}$)	I_D	-7	A
Pulsed Drain Current ⁽¹⁾	I_{DM}	-40	A
Singel Pulsed Avalanche Energy	E_{AS}	-	mJ
Power Dissipation	P_D	3.7	W
Thermal Resistance from Junction to Ambient	$R_{\theta JA}$	33.8	$^\circ\text{C/W}$
Junction Temperature	T_J	150	$^\circ\text{C}$
Storage Temperature	T_{STG}	-55~ +150	$^\circ\text{C}$

MOSFET ELECTRICAL CHARACTERISTICS($T_a=25^\circ\text{C}$ unless otherwise noted)

Parameter	Symbol	Test Condition	Min	Type	Max	Unit
Static Characteristics						
Drain-source breakdown voltage	$V_{(BR)DSS}$	$V_{GS} = 0V, I_D = -250\mu A$	-30	-	-	V
Zero gate voltage drain current	I_{DSS}	$V_{DS} = -30V, V_{GS} = 0V$	-	-	-1	μA
Gate-body leakage current	I_{GSS}	$V_{GS} = \pm 20V, V_{DS} = 0V$	-	-	± 100	nA
Gate threshold voltage ⁽²⁾	$V_{GS(th)}$	$V_{DS} = V_{GS}, I_D = -250\mu A$	-1	-1.5	-2.5	V
Drain-source on-resistance ⁽²⁾	$R_{DS(on)}$	$V_{GS} = -10V, I_D = -10A$	-	16	23	m Ω
		$V_{GS} = -4.5V, I_D = -10A$	-	25	34	
Dynamic characteristics						
Input Capacitance	C_{iss}	$V_{DS} = -15V, V_{GS} = 0V, f = 1MHz$	-	1550	-	pF
Output Capacitance	C_{oss}		-	327	-	
Reverse Transfer Capacitance	C_{rss}		-	278	-	
Switching characteristics						
Turn-on delay time	$t_{d(on)}$	$V_{DD} = -15V, I_D = -6A$ $V_{GS} = -10V, R_G = 2.5\Omega$	-	14	-	ns
Turn-on rise time	t_r		-	20	-	
Turn-off delay time	$t_{d(off)}$		-	95	-	
Turn-off fall time	t_f		-	65	-	
Total Gate Charge	Q_g	$V_{DS} = -15V, I_D = -10A,$ $V_{GS} = -10V$	-	30	-	nC
Gate-Source Charge	Q_{gs}		-	5.3	-	
Gate-Drain Charge	Q_{gd}		-	7.6	-	
Source-Drain Diode characteristics						
Diode Forward voltage ⁽²⁾	V_{DS}	$V_{GS} = 0V, I_S = -10A$	-	-	-1.2	V
Diode Forward current ⁽³⁾	I_S		-	-	-10	A

Notes:

1. Repetitive Rating: pulse width limited by maximum junction temperature
2. Pulse Test: pulse width $\leq 300\mu s$, duty cycle $\leq 2\%$
3. Surface Mounted on FR4 Board, $t \leq 10$ sec

Typical Performance Characteristics

Figure 1: Output Characteristics

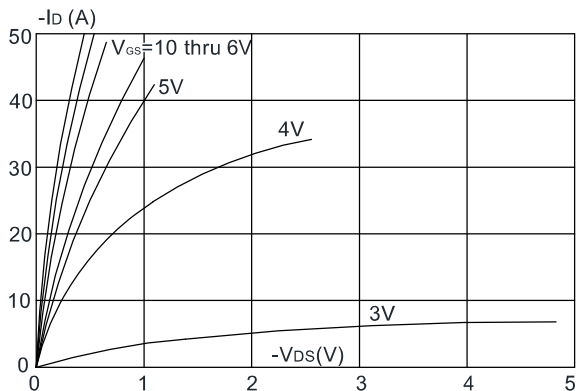

Figure 2: Typical Transfer Characteristics

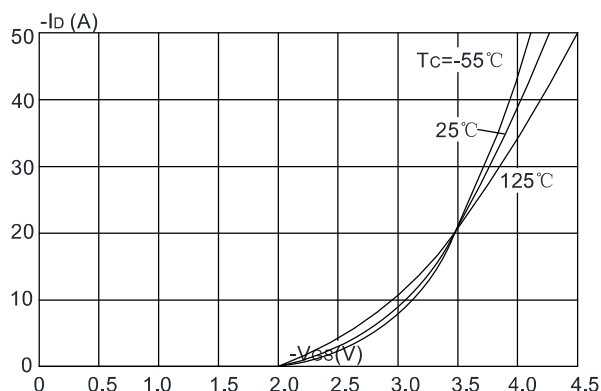

Figure 3: On-resistance vs. Drain Current

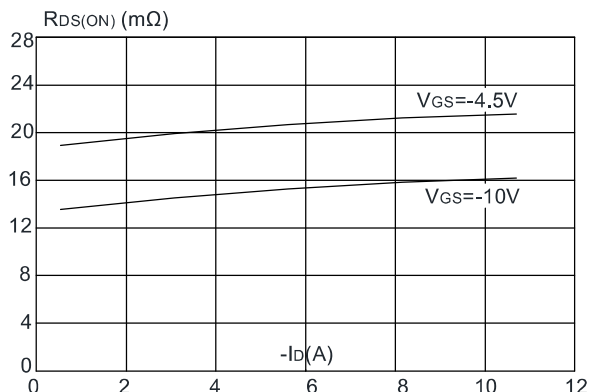

Figure 4: Body Diode Characteristics

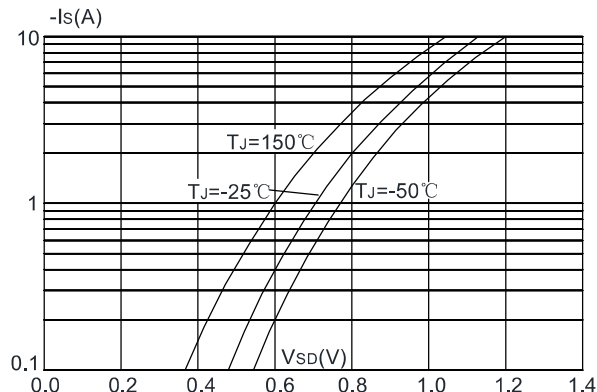

Figure 5: Gate Charge Characteristics

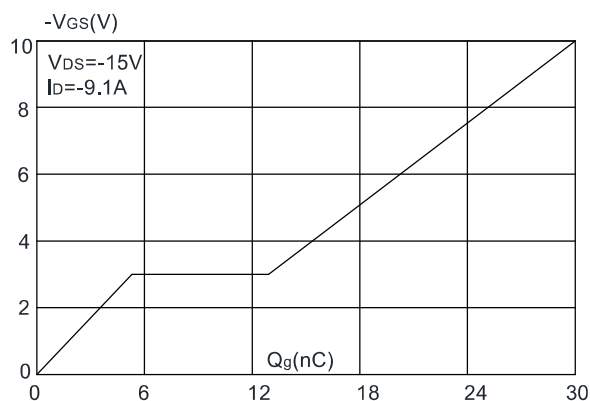

Figure 6: Capacitance Characteristics

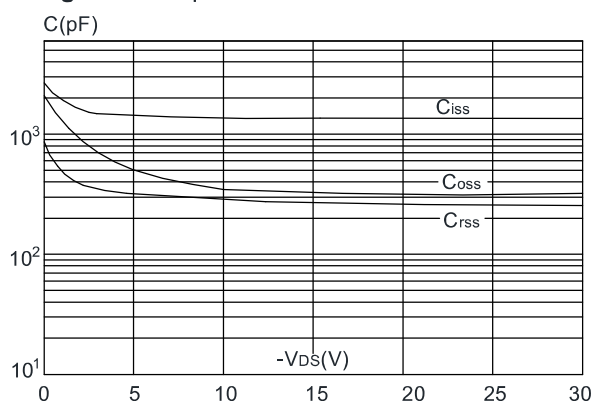

Figure 7: Normalized Breakdown Voltage vs. Junction Temperature

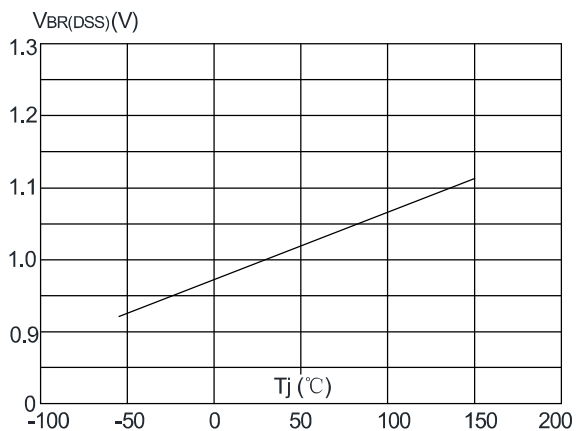

Figure 8: Normalized on Resistance vs. Junction Temperature

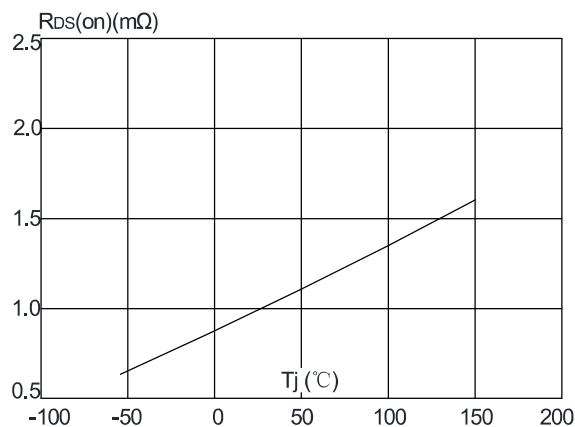

Figure 9: Maximum Safe Operating Area

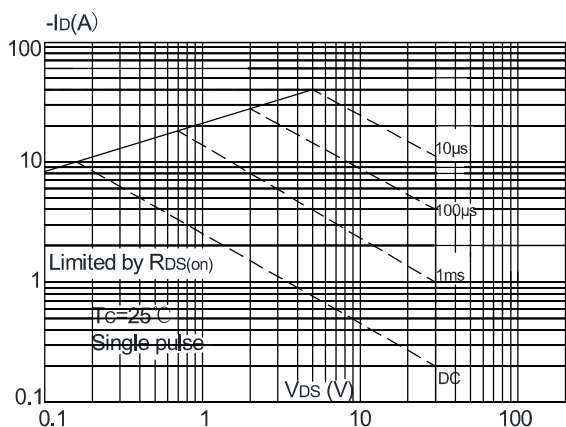

Figure 10: Maximum Continuous Drain Current vs. Case Temperature

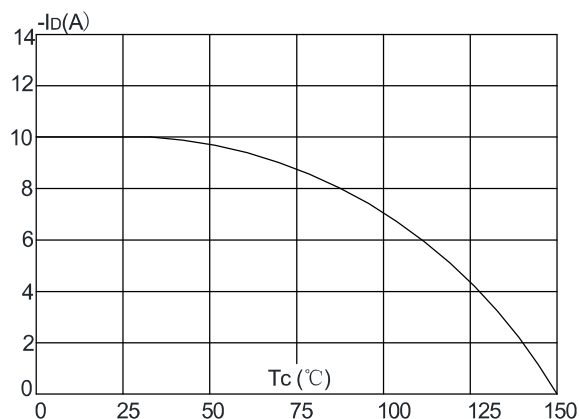
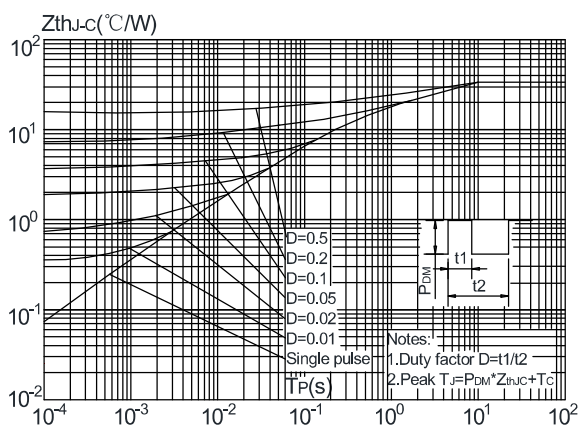
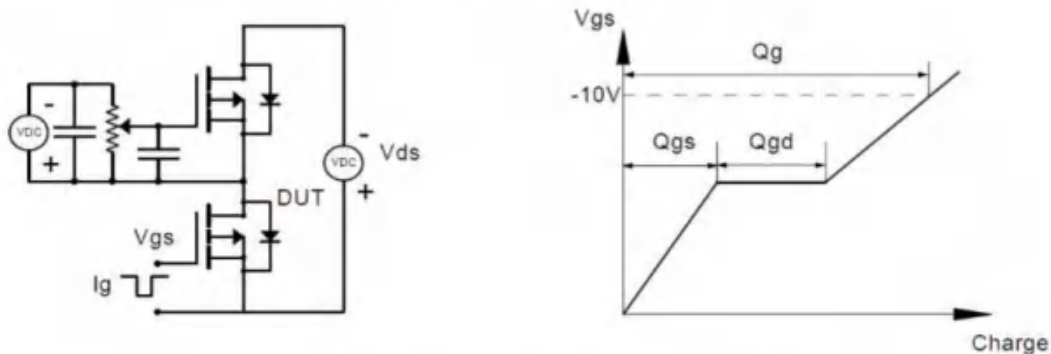

Figure.11: Maximum Effective Transient Thermal Impedance, Junction-to-Ambient



Gate Charge Test Circuit & Waveform



Resistive Switching Test Circuit & Waveforms

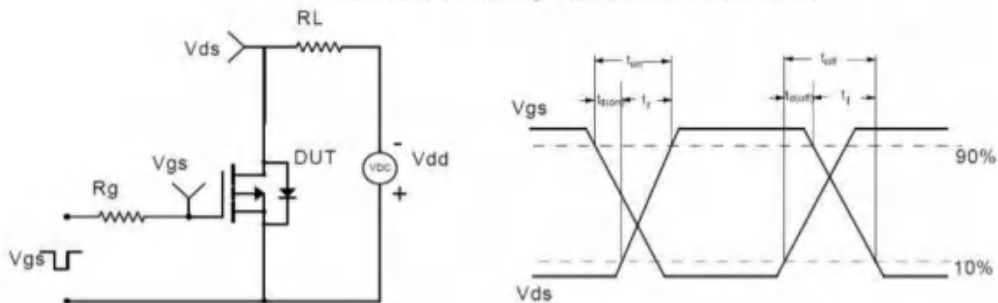

Unclamped Inductive Switching (UIS) Test Circuit & Waveforms

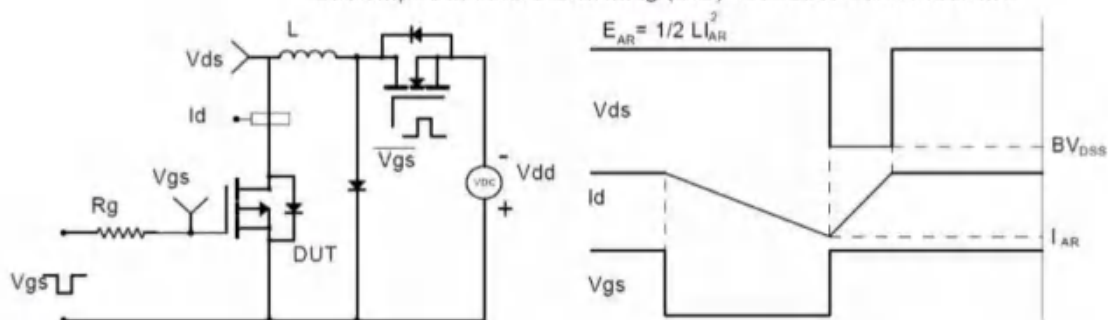

Diode Recovery Test Circuit & Waveforms

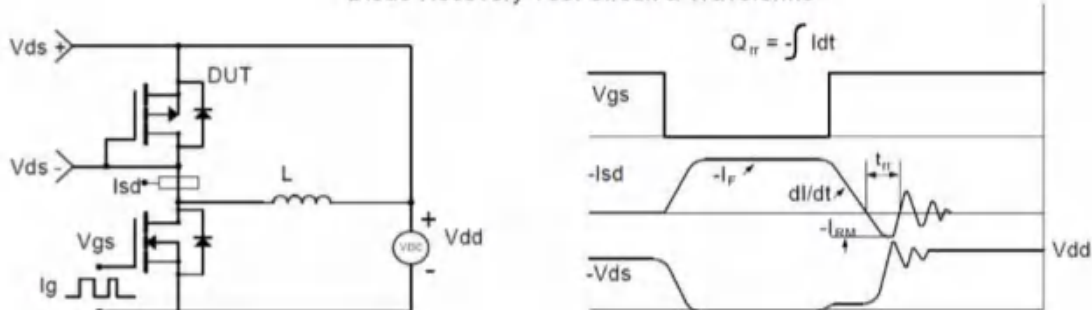

SOT23-3 Package Information

